



Call for Yanmar solutions





> COMPACTNESS

C12R-B

The Yanmar C12R-B is ideal for use on all type of grounds and offers versatility and productivity.

Design principles

- > Compact dimensions:
 - Total width reduced to 960 mm to fit through openings of 1000 mm. New gate lever design integrated within the width of the machine.
 - Length of only 2650 mm.
 - Small turning circle (1810 mm) to work in the narrowest areas.
- > Low center of gravity for higher stability. Machine can travel on slopes of up to 30°.



Dumping

- > High vessel capacity for a very compact machine (0.52 m³ heaped): reduction of the number of round trips on construction sites.
- > Three-way tipping: more efficiency of dumping alongside a trench (less space used).
- > Two pins, easily removable without tools, change the position of side opening. Each gate can be quickly opened with the new lever design.
- > Ample dumping angle (58° on sides - 56° for the rear): enhanced safety when dumping due to single side discharge.



Pin to position the side opening



> HIGH PERFORMANCE

C12R-B



Combining long experience and unrivalled expertise, YANMAR's technology ensures environmental performance and high efficiency.

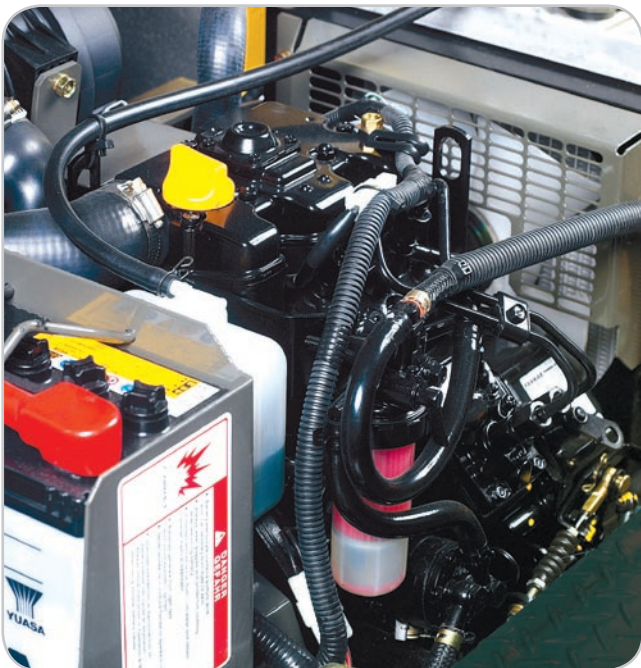

YANMAR engine, TE generation



- > In accordance with the latest noise and environmental norms.
- > 2-cylinder engine, water cooled.
- > Low noise (LwA: only 99 dBA). Reduced operator fatigue. Suitable for urban areas.

Efficiency on all types of terrain

- > Performance on soft and swampy areas.
- > Lower ground pressure due to rubber crawlers and excellent weight distribution. Limited ground damage: the C12R-B is an alternative to wheeled loaders.
- > Rubber crawlers do not damage the asphalt and offer an excellent adhesion on soft grounds.
- > Undercarriage equipped with track rollers with pendular supports to compensate for different ground levels.



> COMFORT

C12R-B

Full operational comfort for ease of operation and work efficiency.

Easy manoeuvring

- > Convenient travelling due to transmission.
- > Quick and safe reversible travel direction due to an easily accessible select lever.
- > Direction of the machine by crawler rotation: 2 travel levers for precise and safe movements.
- > Travel speed select lever (controlling the travel pedal):
 - High speed position: travelling on flat and regular grounds.
 - Low speed position: travelling on difficult grounds (swamp, mud) or on heavy slopes where much more output is required (more traction required).

Ergonomic pilot system

- > Spacious leg room.
- > Easy access to control levers and simple use: reduced operator fatigue after one working day.
- > Access to operating position from either side.
- > Lockable brake pedal acts as a parking brake.

Travel direction select lever

Travel pedal

Brake pedal



> SAFETY

C12R-B



Foldable ROPS structure

- > ROPS structure as standard to protect the operator against rolling over.
- > Quickly foldable without tools by taking off the 2 pins: possibility to travel under low obstacles.



Safety for the operator

- > Safety bar on the top of the vessel for the operator safety during travel on heavy slopes.
- > Seat with safety belt.
- > Wet multiple disk brakes: reliability and durability.
- > Alarm for reverse travel.



- > Safety system on dumping lever: locks the vessel during travel.





> MAINTENANCE

C12R-B

Gate levers



Vessel designed for heavy work

- > The design of the whole structure allows the use of the machine under extreme conditions and increases the machine life:
 - Floor plate thickness: 4.5 mm.
 - Gate post thickness: 3.2 mm.
- > Robust gate levers.
- > Lock bar of dumped vessel for maintenance:
 - Greasing points.
 - Control of hydraulic oil level.
- > Safety bar on the rear of the machine.

Robustness of the undercarriage

- > Long undercarriage for better stability.
- > Excellent weight distribution by 5 reinforced track rollers (for each side).
- > Rubber crawlers with small metal inserts with short pitch: quiet ride and less wear.
- > Crawlers designed to last longer and sufficient elasticity to work on hard grounds (paved road).
- > Easy adjusting of the crawler tension by an adjusting bolt.



Optimum accessibility

- > Large engine hood opening, allowing optimum access to the main engine components.
- > The daily control points (water, engine oil, filters, fan belt...) are positioned to facilitate the maintenance operations.





TECHNICAL SPECIFICATIONS

C12R-B



Operating weight +-2% (EC Norms):
> 1100 kg

Transport weight +-2% (EC Norms):
> 1025 kg

Payload:
> 1150 kg

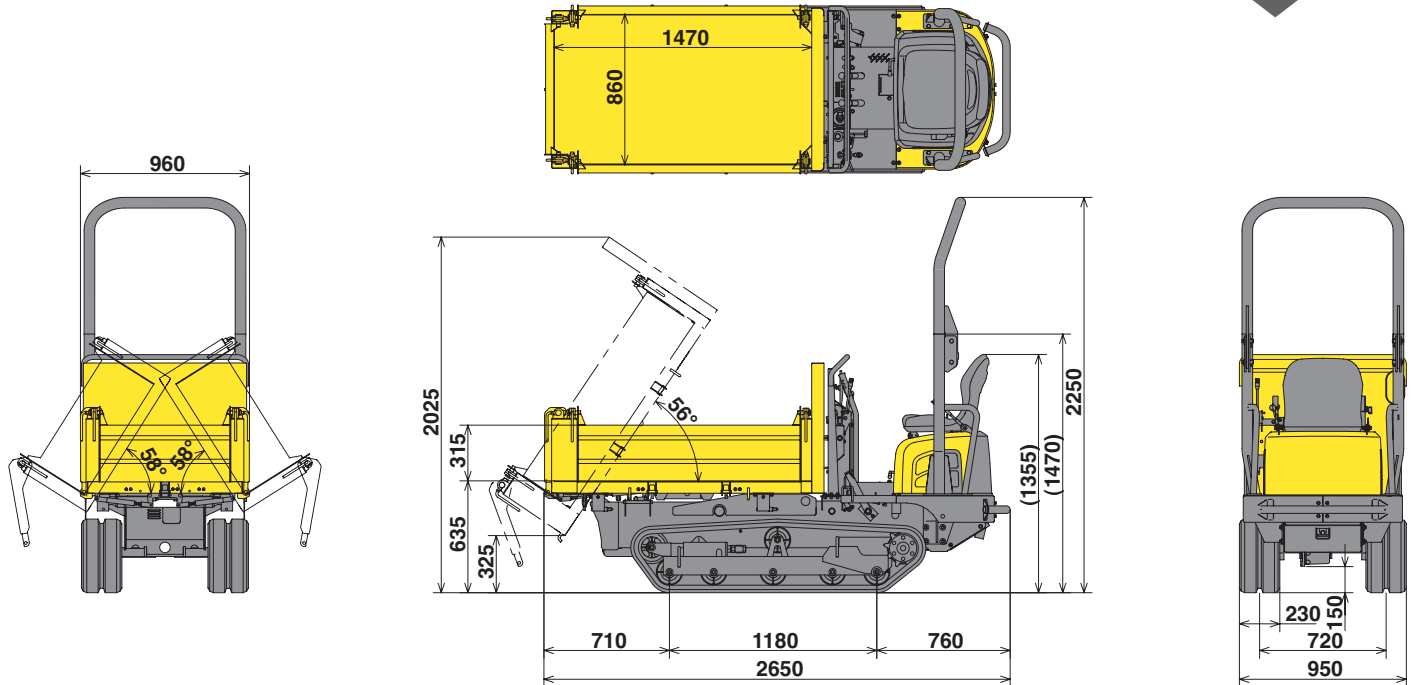

Subject to any technical modifications. Dimensions given in mm.

Engine

Yanmar Diesel 2 cylinders	2TE67L-FW3
Rated Output	7.5 kw / 10.2 HP / 2800 rpm
Displacement	507 cm ³
Max. torque.....	30.8 N.m. / 2200 rpm

Performance

Dumping angle (rear / sideway).....	56° / 58°
Vessel dimensions (L x w x h)	1470 x 860 x 315 mm
Dumping mechanism	3 sides
Dump vessel capacity (struck / heaped)	0.4 / 0.52 m ³
Dump clearance	325 mm
Grade ability	30°
Max. travelling speed (forward / reverse).....	5.5 km/h
Min. turning circle	1810 mm

Undercarriage

Track width.....	230 mm
Ground clearance.....	150 mm
Ground pressure (unloaded / loaded).....	0.20 / 0.41 kg/cm ²

Miscellaneous

Hydraulic tank	16.5 l
Gear pump for dump.....	11.5 l/min x 160 bar
Fuel tank	14.5 l
Hydraulic system.....	2.0 l
Noise Level LwA (2000/14/EC & 2005/88/EC).....	99 dBA



Printed in France – Materials and specifications are subject to change from the manufacturer without notice. Please contact your local Yanmar Construction Equipment Europe dealer for further information.

A&Y Equipment Ltd
01789 414525 | sales@aandygroup.com | www.aandygroup.com