

 **HYDREMA**



Safety Features

912F-SERIES COMPACT DUMP TRUCKS

SAFETY FEATURES

Cab

Meets ROPS requirement
ISO 3471:1994-02

Meets FOPS requirement
ISO 3471:1992-05

3 points of contact for entry
and exit

Laminated windscreen

LED rear lights for safety
and longevity

Air seat /
heated seat:



Operators manual fixed
inside the cab:

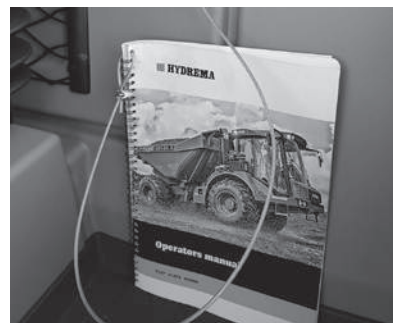

Entry and foot step
lighting:



AC



SAFETY FEATURES

Operational

Operation stability:

The 912F-series is fitted with a unique pivot steering system with anti-roll properties.

Fully adjustable steering wheel:



Dual circuit servo brakes:



Fail Safe parking brake:



Yellow flashing beacon / green seat belt beacon::



All round exterior lightning - std. 8 working lamps, front side and rear:



SAFETY FEATURES

General

Fitted with a reversing camera:



'Tip body up' warning in the dash:



Engine bonnet gas struts:



Reversing alarm:

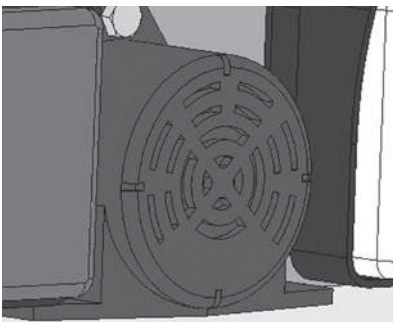

Mechanical 'body stay':



All daily checks can be carried out at ground level:



GPS:



Pivot transportation lock:

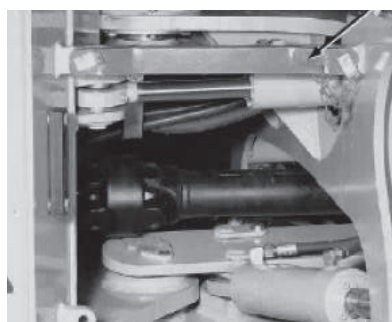

T4 compliant 144 HP Cummins engine:







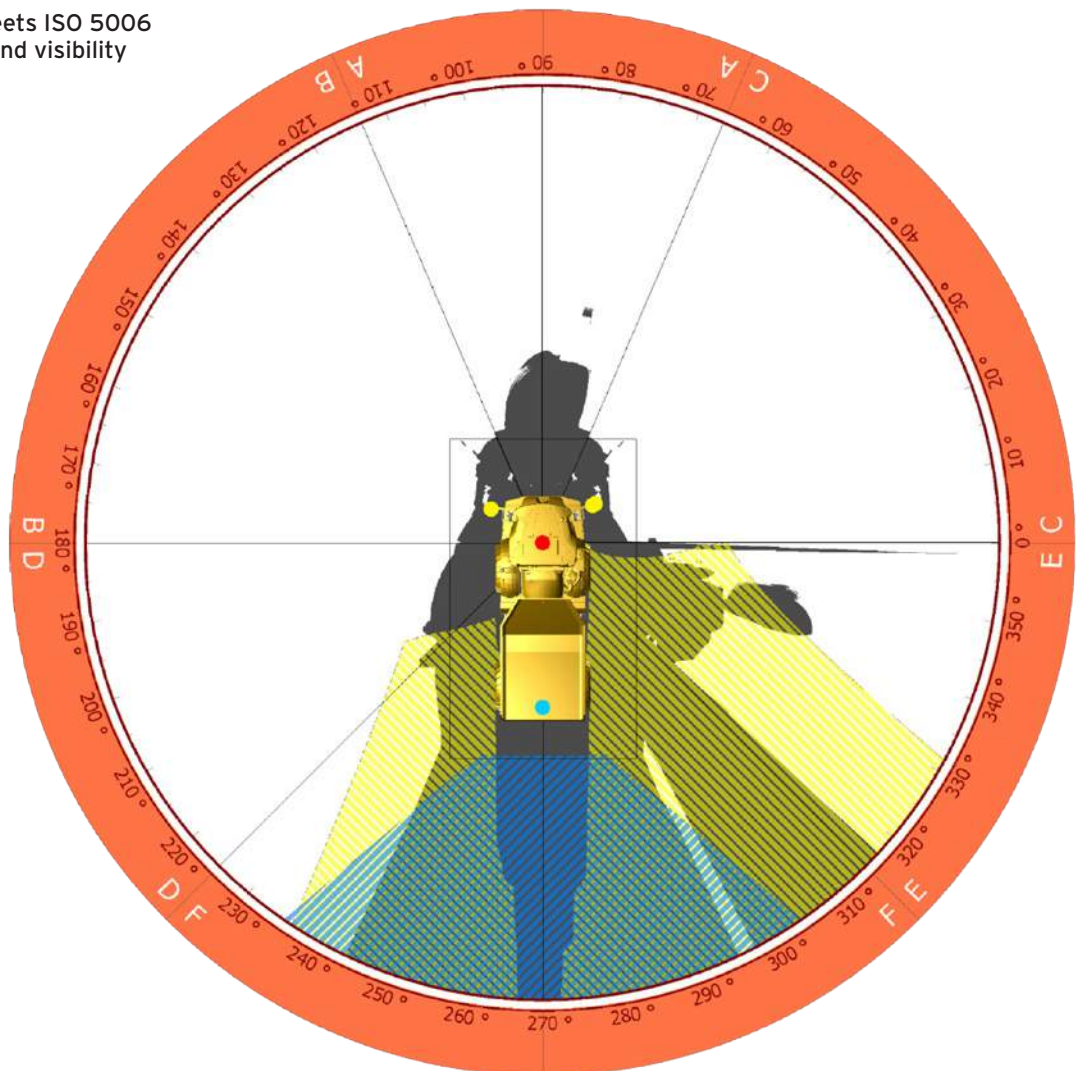

SAFETY FEATURES

Visibility

The 912F-series meets ISO 5006 standard for all round visibility from the cab.



Maskings on RB / test circle		Maskings	
Filament position		Mirror	
Camera		Mirror visibility field	
Camera visibility field			

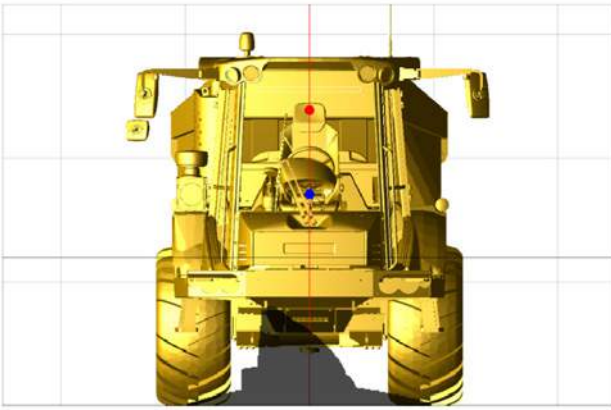

Maslings on RB		Maslings	
Filament position		SIP - Seat Index Point	
Vertical sight of 200.0mm		Mirror visibility field	
Camera visibility field			

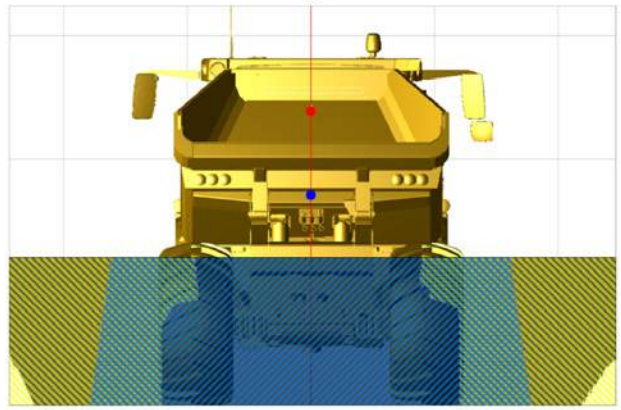

Maslings on RB		Maslings	
Filament position		SIP - Seat Index Point	
Vertical sight of 200.0mm		Mirror visibility field	
Camera visibility field			

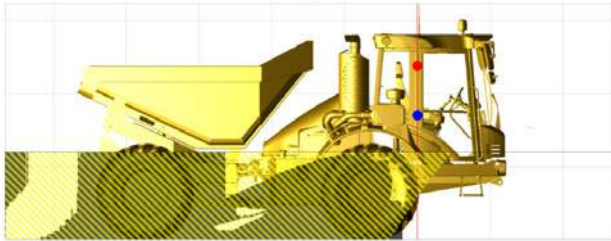

Maslings on RB		Maslings	
Filament position		SIP - Seat Index Point	
Vertical sight of 200.0mm		Mirror visibility field	
Camera visibility field			

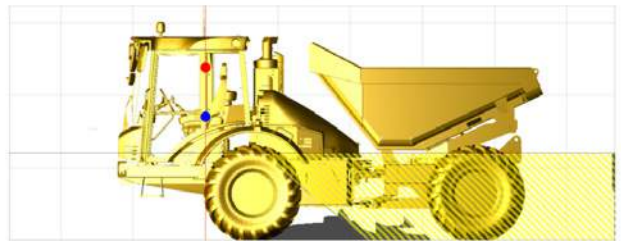

Maslings on RB		Maslings	
Filament position		SIP - Seat Index Point	
Vertical sight of 200.0mm		Mirror visibility field	
Camera visibility field			

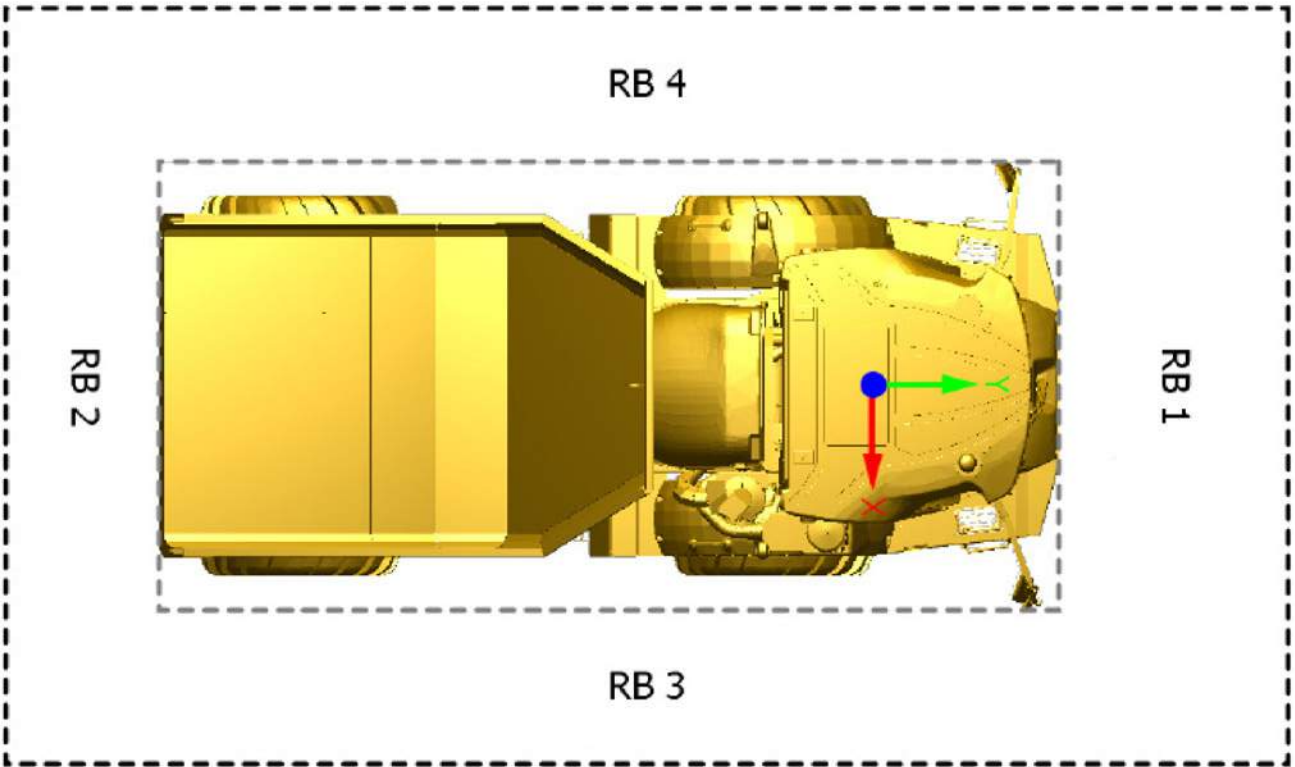

Maslings on RB		RB	
SIP - Seat Index Point			

SAFETY FEATURES

Options

Tip preventor
inclinometer:



Xenon
lightning:



Wide angle
convex mirrors:



360° camera:

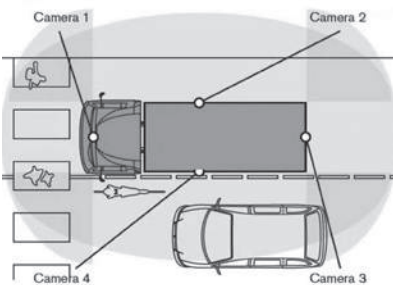

Wheel nut
indicators:



Fire
extinguisher:



White noise
reversing alarm:



Blue
quarry lighting:





HYDREMA UK LTD.
Call +44 01765 641 940

MORE INFO
www.hydrema.com

 **HYDREMA**