

# Excellent stability



The ViO12 has an operating weight of 1220 kg and the longest undercarriage of its class with 1440 mm. This results in a real improvement of the operator's comfort. He benefits from a smoother drive and increases his productivity.

The machine is also more stable with heavy loads or attachments. This is very important for key applications for this type of mini-excavator, such as demolition.

## BEST COMPONENTS

All ViO12 components are designed in order to make it reliable, durable and capable of performing demanding work.



# Technical specifications

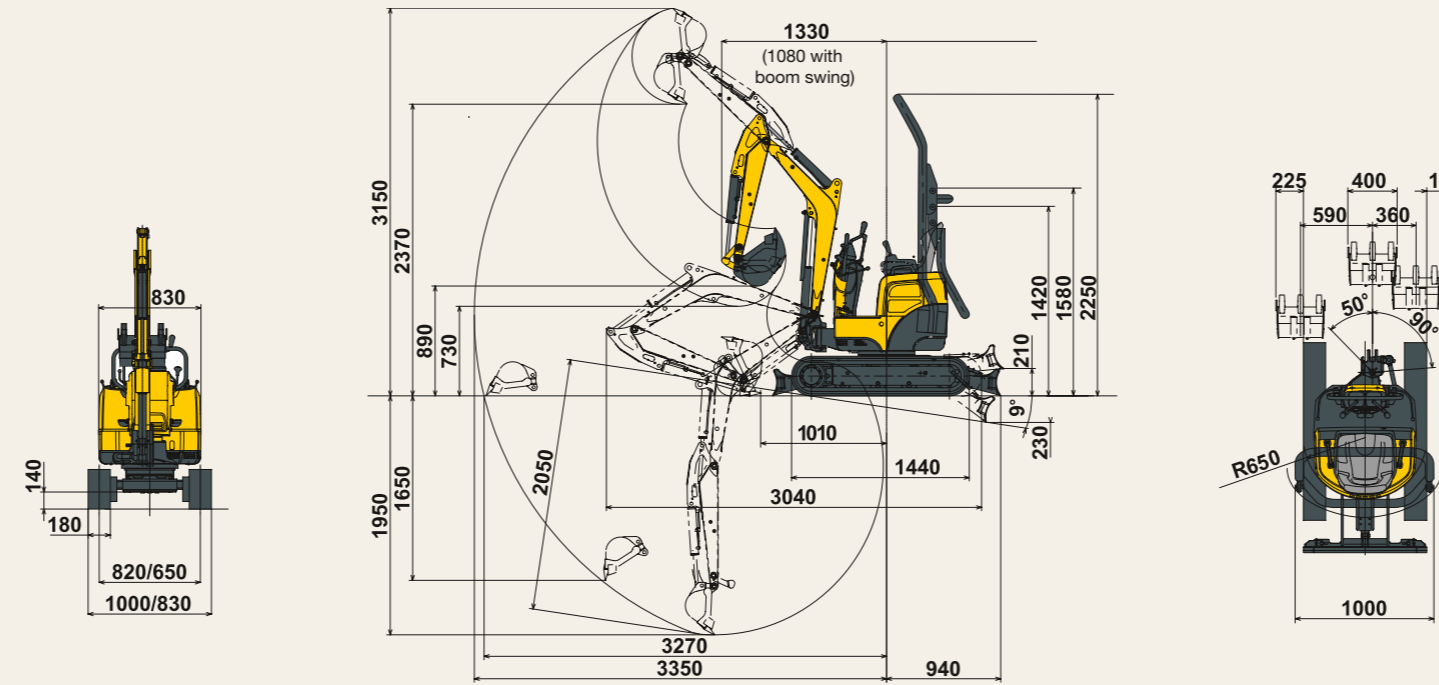

Engine	
Yanmar diesel 3 cylinders	3TNV70-WBVB
Rated output	9.2 kw/12.5 HP/2000 rpm
Displacement	854 cm <sup>3</sup>
Max. torque	52 N.m./1600 rpm
Hydraulic circuit	
System capacity	14.3 l
Max. pressure	210 bar
Variable flow dual piston pump	2 x 11 l/min
Performances	
Travelling speed	2.1 km/h
Swing speed	10 rpm
Digging force (arm/bucket)	570/1400 kgf
Boom swing (L/R)	50°/90°
Ground pressure	0.26 kg/cm <sup>2</sup>
Grade ability	30°
Shoe width	180 mm
Ground clearance	140 mm
Blade (width x height)	830/1000 x 220
Miscellaneous	
Fuel tank	12 l
Cooling system	2.5 l
Transport dimensions (L x w x h)	3040 x 1000 x 1420 mm
Noise level LwA	88 dBA

Blade on ground												
A	Maxi		2.5 m		2.0 m		1.5 m					
B	W	N	W	N	W	N	W	N	W	N	C	
2.0	*185	115	*185	*185	120	*190	*185	145	*185	-	-	-
1.5	125	95	230	155	120	*205	*205	165	*205	-	-	-
1.0	115	90	*230	145	115	*240	200	160	*270	*380	255	*370
0.5	110	85	*245	145	100	*270	195	150	*345	305	210	*550
0	115	85	*260	140	100	*305	185	140	*385	275	205	*600
-0.5	125	90	*280	145	105	*305	180	135	395	260	210	615

Blade above ground												
A	Maxi		2.5 m		2.0 m		1.5 m					
B	W	N	W	N	W	N	W	N	W	N	C	
2.0	*185	110	*185	*185	120	*190	*185	145	*185	-	-	-
1.5	125	90	160	155	115	*205	205	160	*205	-	-	-
1.0	115	85	145	145	110	180	200	155	*265	380	245	*365
0.5	110	80	130	145	100	170	195	145	230	305	200	355
0	115	80	140	135	100	175	185	140	230	270	200	335
-0.5	125	90	155	140	100	165	175	130	215	260	200	330

Printed in France – Materials and specifications are subject to change from the manufacturer without notice – Please contact your local Yanmar Construction Equipment Europe dealer for further information.

GB\_VIO12\_0416



YANMAR



Simply the best



Engine	3TNV70-WBVB
Net Power	12.5 HP
Operating Weight	1220 kg
Tear-out force	5.6 kN
Breakout force	13.7 kN

# Design



## JOYSTICKS



### IMPROVED ERGONOMICS

The use of joysticks on both sides of the seat enables to improve the position of the operator, therefore enhancing his comfort while working.

With the joysticks, the operator also has a better control over the machine movements. Manoeuvrability, productivity and precision are increased.

### SIMPLICITY AND ROBUSTNESS

Yanmar decided to use the same tried and tested joysticks as for its heavier mini-excavators. This well-conceived system offers the following features:

- Less risk of damages and downtime
- Longer service life

### OTHER FEATURES

- Operating weight: 1220 kg
- Longest undercarriage of its class with 1440 mm
- Extendable undercarriage of unique conception: reduced clearance between the sliding parts, no soil build-up during the extension of undercarriage.
- Simple folding extendable blade
- A large engine bonnet allows quick access to the main components



## KINEMATICS



# Leading performance

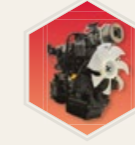

## ENGINE

The VI012 is equipped with a Yanmar diesel engine 3TNV70 which delivers a power of 9.2 kW and has a torque of 52 Nm. This enables to improve highly the performance of the machine.



## HYDRAULICS

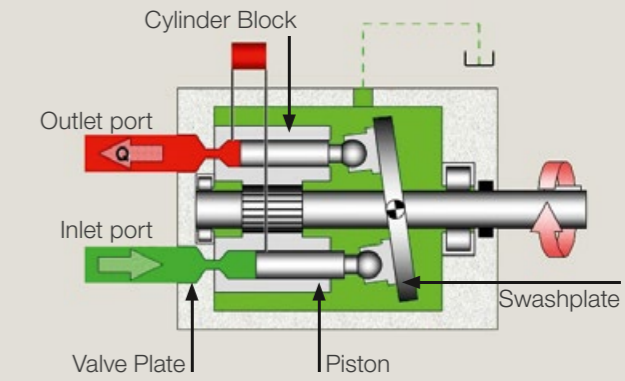

Unlike industry standards for this category of machines, Yanmar is using variable axial piston pump which adapt the flow and the pressure to the load, allowing smoother operation and improving the comfort of the operator. The pump flow of 2 x 11 l/mn and its high working pressure (210 bar) also enable to improve the productivity of the machine and its speed in working motion.



## PERFORMANCE

The attention paid to the quality of the power line ensures excellent performance while the optimal combination of the VI012 excavation strengths and work cycles assures exceptional productivity.

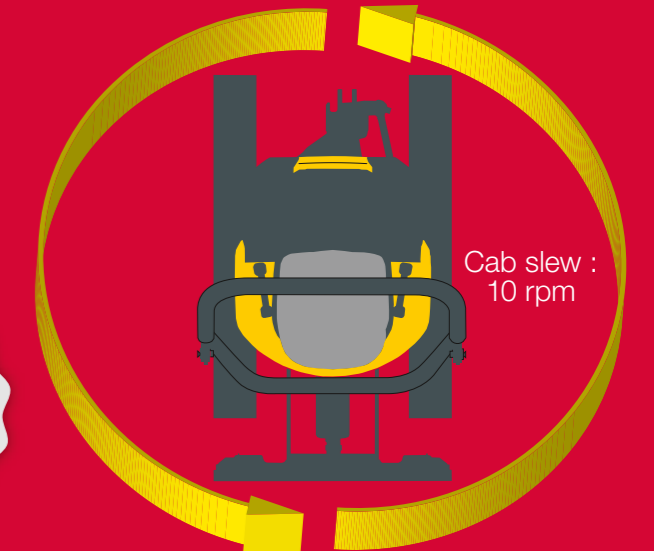

## CUSTOMER BENEFITS



**BETTER PERFORMANCE**



**IMPROVED CYCLE-TIMES**



**INCREASED PRODUCTIVITY**