

MACHINES

ARW WALK-BEHIND ROLLERS

ARW SERIES WALK-BEHIND ROLLERS

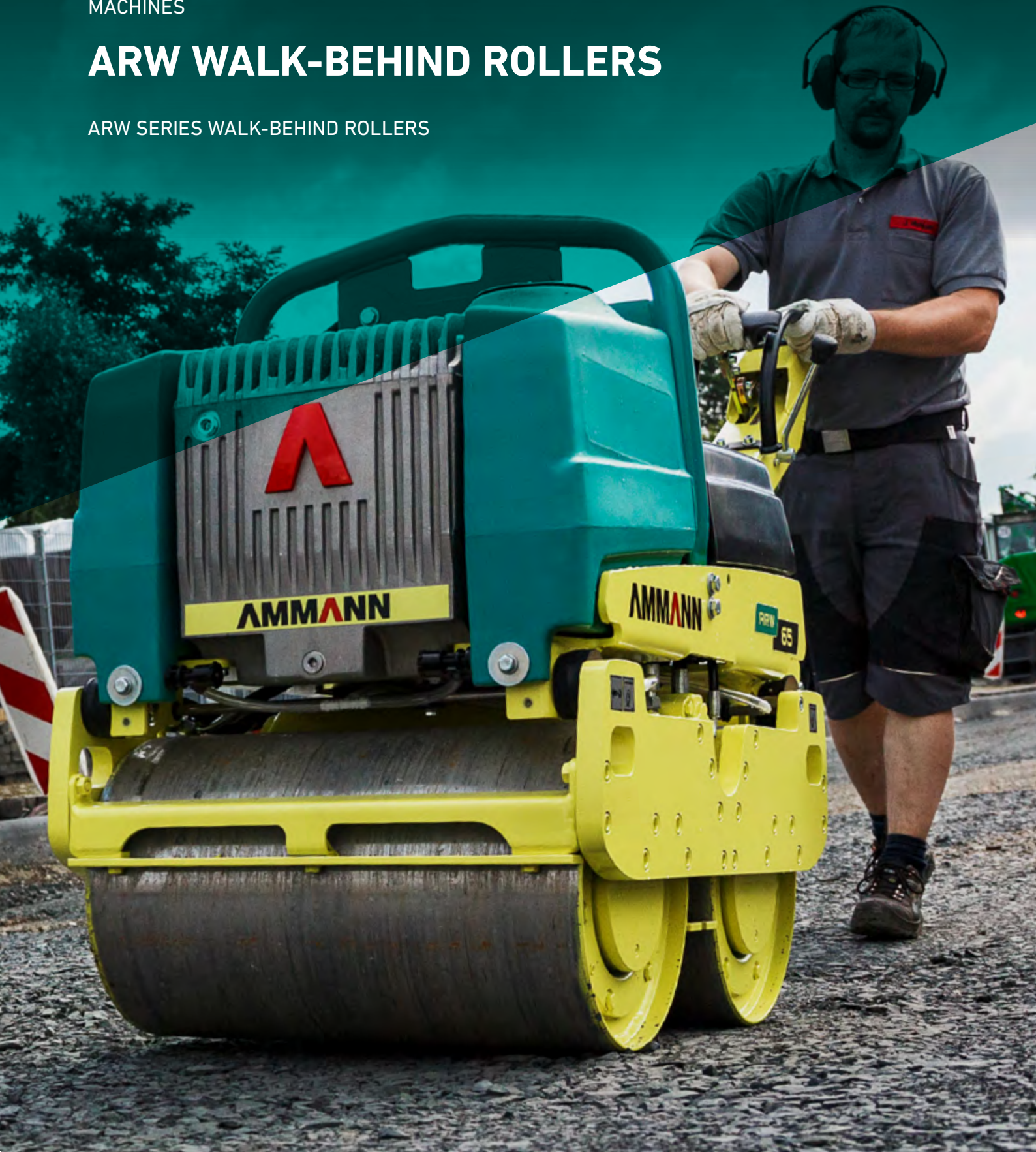

Equipment Ltd

01789 414525 | sales@aandygroup.com | www.aandygroup.com

AMMANN

THE RIGHT FIT ON YOUR JOBSITE

AMMANN ARW WALK-BEHIND ROLLERS

Walk-behind vibratory rollers from Ammann offer two applications in one machine. The operator can choose between a high amplitude for working on substructures and a low amplitude for compacting asphalt and bituminous material. Walk-behind rollers are available with two different diesel engines. Both are powerful and fulfill the applicable world-wide emission standards.



ARW 65 HATZ

OPERATING WEIGHT CECE: 719 kg
DRUM WIDTH: 650 mm
MAX. VIBRATING FREQUENCY: 60 Hz
MAX. CENTRIFUGAL FORCE: 11 / 21 kN



ARW 65 YANMAR

OPERATING WEIGHT CECE: 712 kg
DRUM WIDTH: 650 mm
MAX. VIBRATING FREQUENCY: 60 Hz
MAX. CENTRIFUGAL FORCE: 11 / 21 kN



YOUR BENEFITS AT A GLANCE

WHAT CHARACTERISES THE
WALK-BEHIND ROLLERS FROM AMMANN?

EFFICIENCY

2 amplitude settings

Enables different applications such as asphalt work or compaction work on substructures or non-bonded base layers

Fully hydraulic machine

Precise speed adjustment

Full side clearance

Accurate, infinitely variable working next to walls and kerbs

Integrated sprinkler system

Prevents asphalt from caking on the drums

ERGONOMICS

Dead man handle

Operators work in safety

Automatic parking brake

Prevents the machine from rolling away

Height-adjustable guide handle

Optimises operating comfort for operators of any height

Maximum reversing speed reduced to 2.5 km/h

Enables controlled working in reverse mode

SERVICEABILITY

Simplified maintenance work

Daily maintenance work does not require special tools

Drive without wear parts

The fully hydraulic drive system works without a high-maintenance centrifugal clutch and V belt





ADJUSTABLE ECCENTRIC WEIGHTS

EFFICIENCY ON EVERY SUBSTRATE

The roller is suitable for use on substructures and asphalt surfaces. Adjustable eccentric weights for setting the amplitude and an integrated, generously dimensioned 60-litre water tank as standard guarantee that the machine is always ready for use and can switch quickly from loose substrate to asphalt. The ARW from Ammann is therefore the ideal addition to any machine pool.

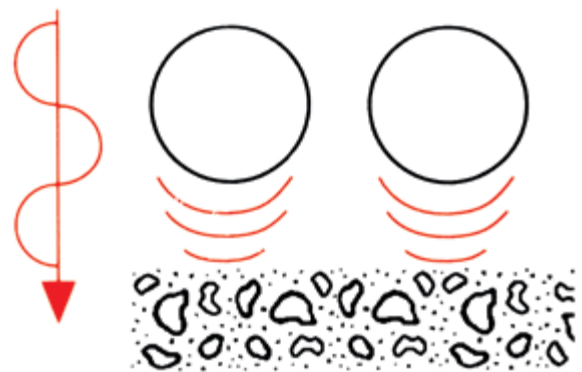
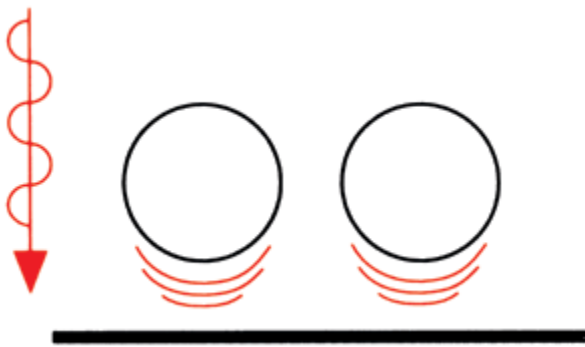
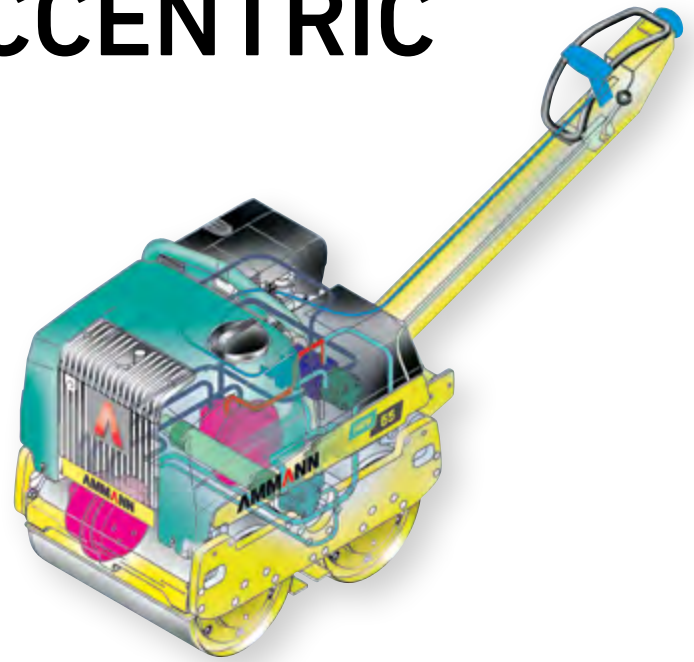

TECHNICAL SOLUTIONS FOR YOUR JOBSITE

ADAPTABLE TO YOUR NEEDS

Quality and productivity are prerequisites for good construction machines. Ammann machines offer both and stand out through ease of operation. Numerous options guarantee every customer has the ideal machine for his area of use.



HOURS-RUN METER

The next service date can be scheduled well in advance thanks to a continuous display of hours run.



ELECTRIC START

(STANDARD ON THE YANMAR VERSION,
OPTIONAL ON THE HATZ VERSION)

Starting the machine is easy with the E-starter. Cranking the machine before starting work is no longer necessary.



ARW 65

WALK-BEHIND ROLLERS

FLEXIBILITY FOR YOUR MACHINE POOL

The ARW 65 offers two applications in one machine to optimise your cost of investment.

The high amplitude setting makes the walk-behind roller ideal for compacting soil and substructures. The operator can switch to a lower amplitude that is perfect for compacting asphalt and bitumen. The machine is always ready for working on bituminous surfaces thanks to a scraper and a 60 litre water tank with sprinkler system.

The ARW 65 is available with engines from Hatz and Yanmar. These powerful diesel engines guarantee good driving properties even in difficult terrain.

The Yanmar version comes with an electric starter as standard. The Hatz version offers an electric starter as an option.



HIGHLIGHTS

- Hydrostatic drive and vibration system
- Hydrostatically adjustable eccentric weights for machine use on substructures and bituminous surfaces
- Hydraulic pump for the hydrostatic drive and steering; no V belt required
- Ergonomic guide handle with dead man handle for even more safety
- Large 60-litre water tank for compacting bituminous surfaces
- Easily accessible maintenance points



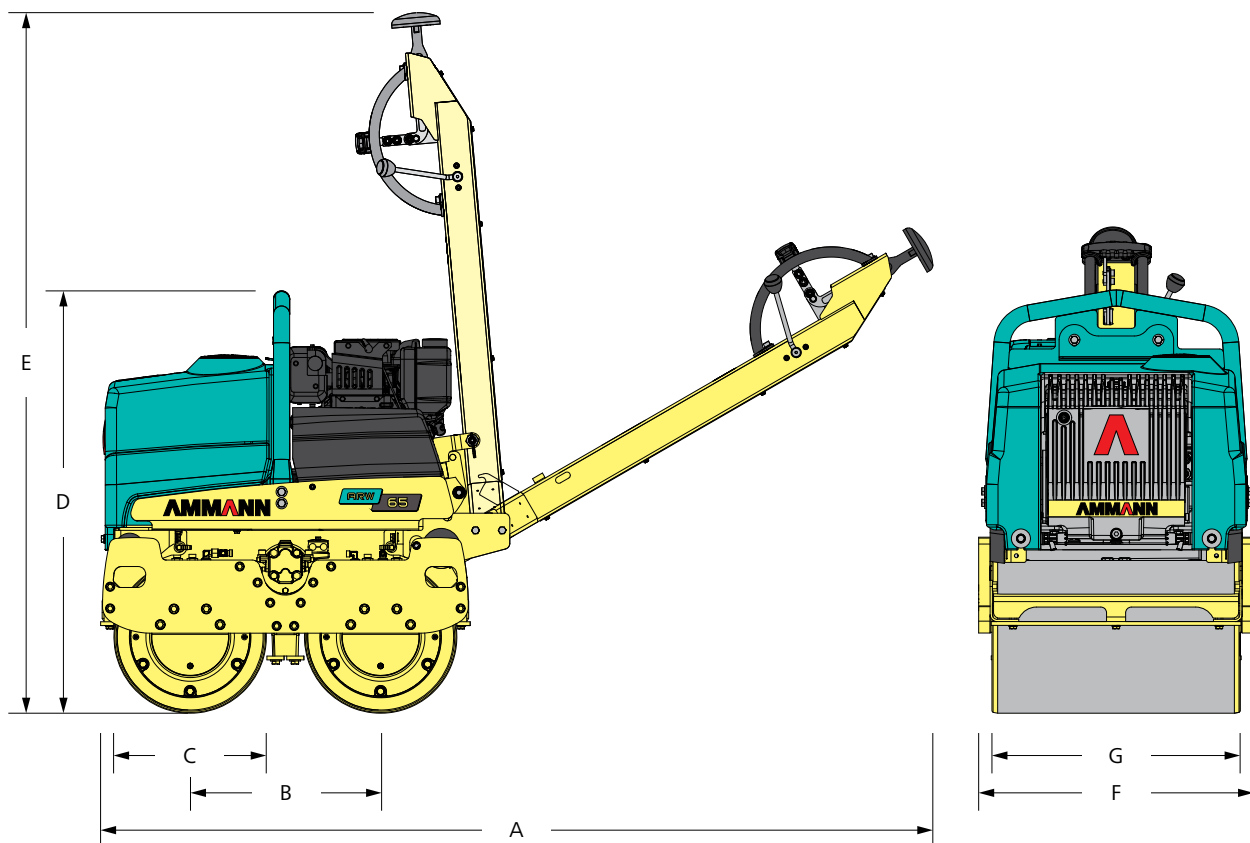

DIMENSIONS & WEIGHT

	ARW 65 Hatz	ARW 65 Yanmar
OPERATING WEIGHT CECE	719 kg	712 kg
NET WEIGHT, STANDARD VERSION	687 kg	679 kg
A MACHINE LENGTH	2288 mm	2288 mm
B DRUM SPACING	500 mm	500 mm
C DRUM DIAMETER	400 mm	400 mm
D MACHINE HEIGHT	1110 mm	1110 mm
D TRANSPORT HEIGHT	1835 mm	1835 mm
F MACHINE WIDTH	720 mm	720 mm
G DRUM WIDTH	650 mm	650 mm

COMPACTION OUTPUT

MAX. VIBRATING FREQUENCY	60 Hz	60 Hz
MAX. CENTRIFUGAL FORCE	11/21 kN	11/21 kN
LINER PRESSURE	5 kg/cm	5 kg/cm
MAX. COMPACTION DEPTH (SOIL)	20/15 cm	20/15 cm
MAX. COMPACTION DEPTH (SAND)	30/25 cm	30/25 cm

* depending on ground conditions

ENGINE

	ARW 65 Hatz	ARW 65 Yanmar
ENGINE	Hatz 1D42S	Yanmar L100N
FUEL	Diesel	Diesel
ENGINE OUTPUT AT RPM	6.1 kW, 8.3 HP 2800	6.1 kW, 8.3 HP 2600
FUEL CONSUMPTION	1.7 l/h	1.2 l/h

MISCELLANEOUS

SPEED (FORWARDS)	4 km/h	4 km/h
SPEED (REVERSING)	2.5 km/h	2.5 km/h
GRADEABILITY WITH / WITHOUT VIBRATION	25 % / 45 %	25 % / 45 %
FUEL TANK VOLUME	5 l	4.7 l
HYDRAULIC OIL TANK VOLUME	20 l	20 l
WATER TANK VOLUME	60 l	60 l

“The ARW 65 is one of the most versatile machines on the market. It delivers optimum compaction results on substructures and asphalt surfaces.”

